



### Summary

EasyBee is an IEEE 802.15.4 compliant RF transceiver. It enables designers to easily add ZigBee / IEEE 802.15.4 wireless capability to their products without the need for RF or antenna design expertise.

The module contains all RF circuitry, including integral antenna and controller in a simple-to-use, plug-in or surface mount module. A 4-wire SPI port interfaces to a baseband microcontroller.

The PHY (Physical) layer includes an impedance matched balun and integral antenna. The MAC (Media Access Control) layer includes CRC-16 generation, clear channel assessment, signal energy detection, security, encryption and authentication.

EasyBee is a fully capable device and a ZigBee networking layer is not required for point-to-point communication. If ZigBee is required, compatible ZigBee stacks include Microchip Technology's free ZigBee stack, and Figure-8's ZigBee stack.

This module is an application-ready solution for fast-to-market ZigBee and IEEE 802.15.4 communications, providing the development engineer unlimited choice of host controller and stack firmware provider.

### Features

- 2.4GHz IEEE 802.15.4 / ZigBee RF module
- Free space range approx 120m
- Raw data rate 250kbps
- FCC / CE compliance planned
- Integral antenna
- Based on ChipCon CC2420 RF controller:
  - 4-wire SPI interface
  - separate 128-byte Rx & Tx FIFO buffers
- For ZigBee use controller of developer's choice, e.g. PIC running Microchip stack or ATMEL running Figure-8 stack
- Output power 1mW / 0dBm
- Consumes just 20mA (Rx), 18mA (Tx)
- 2.1V – 3.6V supply
- Surface mount or with PCB headers
- Wide temperature range -40°C to +85°C
- Just 26mm x 20mm

### Applications

- IEEE 802.15.4 & ZigBee networks
- Cable replacement
- Home / building automation
- Industrial control & networking
- Wireless sensor networks

### Ordering Information

Table 1. Ordering information	
Part No	Description
EASYBEE SO	EasyBee 18-contact surface mount module
EASYBEE DIL	EasyBee 18-pin 0.1" Dual-in-Line module
EVAL EASYBEE	EasyBee daughter card for Microchip Technology's PICDEM-Z ZigBee development kit
Contact us for information on all-weather enclosures	

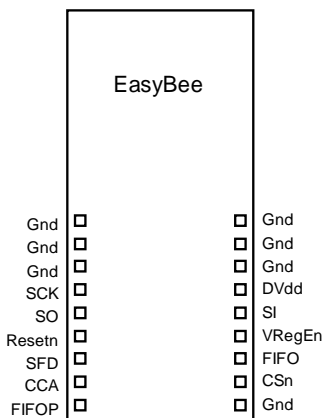

Manufactured to ISO9001:2000



## Contents

Summary .....	1	Mechanical .....	4
Electronic .....	2	Bibliography .....	5
Regulatory .....	3	Drawing .....	6
Radio Frequency .....	4	Reference .....	7

## Electronic

### Pin Connections

<b>Pin Number</b>	<b>Pin Name</b>	<b>Description</b> (note 1)
1,2,3	<i>Gnd</i>	Power supply ground reference and ground plane connection
4	<i>SCK</i>	SPI clock input, up to 10 MHz
5	<i>SO</i>	SPI slave output. Updated on the negative edge of SCLK. Tristate when <i>CSn</i> high.
6	<i>Resetn</i>	Asynchronous, active low digital reset
7	<i>SFD</i>	SFD (Start of Frame Delimiter)
8	<i>CCA</i>	CCA (Clear Channel Assessment) (Note 2)
9	<i>FIFOP</i>	High when number of bytes in FIFO exceeds threshold
10	<i>Gnd</i>	Power supply ground reference and ground plane connection
11	<i>CSn</i>	SPI chip select, active low
12	<i>FIFO</i>	High when data in FIFO
13	<i>VregEn</i>	Voltage regulator enable, active high, held at <i>DVdd</i> voltage level when active
14	<i>SI</i>	SPI Slave Input. Sampled on the positive edge of SCLK
15	<i>DVdd</i>	Power supply input 2.1V – 3.6V
16,17,18	<i>Gnd</i>	Power supply ground reference and ground plane connection

**Table 1. Pin descriptions for EasyBee**

1. Refer to CC2420 documentation for further details of these pin function. (See bibliography)
2. In early revisions of this board, the CCA pad is not connected on the underside. If this pad is required in surface mount applications, connection shall have to be manually reworked from the top pad. This affects boards which do not have 'Rev D' or higher marked on them.

## Functional Block Diagram

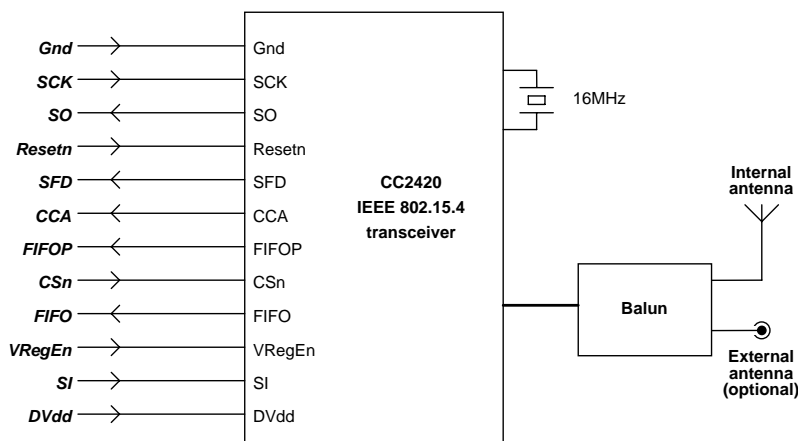

Figure 2. eZBee Functional Block Diagram

### Circuit Description

The functional block diagram in figure 2 summarizes the electrical EasyBee module. The actual circuit closely follows the reference design specified by ChipCon AS for single ended operation with discrete balun. (See bibliography.) Actual component choices may differ.

The module is also electrically identical to the PICDEM Z radio board supplied by Microchip Technology Inc. The main difference is the smaller size.

If the device being designed is to be battery powered, aim to use lithium batteries rather than alkaline since they generally have much better ageing characteristics and reduced voltage decline over their lifetime.

### Interfacing to the RF module

Refer to ChipCon's documentation for information on how to interface to the CC2420 module. Most ZigBee stack firmware also details how to communicate with the CC2420 using the SPI port.

### Development Kits

OEMs intending to use EasyBee with Microchip PIC microcontrollers can use the PICDEM Z ZigBee development kit available from Microchip Technology. Microchip also provide a free ZigBee stack. The *EasyBee DEMO* version of the module is designed to plug directly into the PICDEM Z motherboard. Migration to EasyBee simply requires choosing an appropriate PIC microcontroller for the application.

OEMs wanting to use EasyBee with other baseband microcontrollers should use ZigBee stack software which is designed for interfacing to the CC2420 chip. An example is Figure8's ZigBee Stack ([www.figure8wireless.com](http://www.figure8wireless.com)), which has a development kit is available.

Circuit diagnosis is much aided through the use of a packet sniffer such as Pixie Sniffer. Pixie Sniffer is freely available from FlexiPanel Ltd for use with Pixie modules and PIXDEM-Z.

### Regulatory

#### EMI ratings

EasyBee has been independently tested for FCC, CE and IC (Industry Canada) compliance.

FCC compliance requires us to state the following:

1. *This device complies with Part 15 of the FCC Rules. Operation is subject to the following two conditions: (1) this device may not cause harmful interference, and (2) this device must accept any interference received, including interference that may cause undesired operation.*

- OEM products incorporating EasyBee must include an external label containing the following text legible to the naked eye:

**Contains Transmitter Module  
FCC ID:UGAZBMR10**

- Changes or modifications to the module may void its certification.

### OUI number / MAC address

All IEEE 802.15.4 devices such as EasyBee must use a unique 8-byte MAC address. The first 3 bytes (the 'OUI' number) are licensed to a company by IEEE for an annual fee. The licensee is then free to uniquely assign the remaining 5 bytes.

FlexiPanel Ltd can provide MAC addresses under its OUI license for the transceivers it manufactures. OEMs therefore do not need to apply for an OUI number. FlexiPanel Ltd's OUI number is 00-15-C8.

For R&D purposes (i.e. in the lab or classroom), the following MAC addresses may be used:

00:15:C8:38:41:00:00:00 to 00:15:C8:38:41:00:FF:FF

For commercial purposes, contact FlexiPanel Ltd or your distributor for an allocation of MAC addresses.

## Radio Frequency

### Optimizing RF Performance

The integral antenna supplied with Pixie is a modified quarter wave F antenna with efficiency of approximately 70%. This is comparable to a dipole and about as high as physically possible. Its radiation pattern is approximately omnidirectional.

Free space range is approximately 120m. In-building ranges of 20m to 40m would normally be expected.

The enclosure employed may affect antenna performance. Avoid the use of metal enclosures. Gray and black plastics should be used with caution. They often contain carbon, which degrades performance considerably. To test for the presence of carbon, heat the plastic in a microwave oven for one minute. If it melts, it probably contains carbon.

A high location is recommended, particularly for avoiding interference from transient objects such as passers-by and their cellphones. Microwave ovens are particularly problematic for the short periods in which they are operational. Where possible, orient all the antennas in the same direction so that their polarizations are the same. In a mesh network, a highly attenuating medium such as a floor may be bridged by placing two routers close to each other, one on either side of the barrier.

Material	Reduces range by factor of
Reinforced concrete floor	30
Brick wall with window	1.25
Office wall	2
Metal cabinet	3
5mm potting compound	2 - 3
Vegetation	1.25 per meter

*Compact materials, e.g. humans, have a complex effect, In general attenuating most noticeably when closest to the antenna.*

## Mechanical

### PCB Layout

For PCB pad layout, refer to the engineering drawing on page 6. Note how the pads on the main board protrude out from beneath the module. This provides a point to apply heat when manually soldering and also for continuity testing. In addition, the size of the pad ensures a large reservoir of solder is available to the actual contact area.

### Soldering

If soldered using a reflow oven, the surface mount module may be treated like a BGA package. The quality of the joint may be tested by checking for continuity between the pad on the upper side of the board and the protruding part of the pad on the main board.

The recommended reflow profile is shown in figure 3. Small increases in temperature (no larger than 15°C) may be needed depending on the density of the main board. The module should be reflowed one time only.

Figure 3. Recommended reflow profile

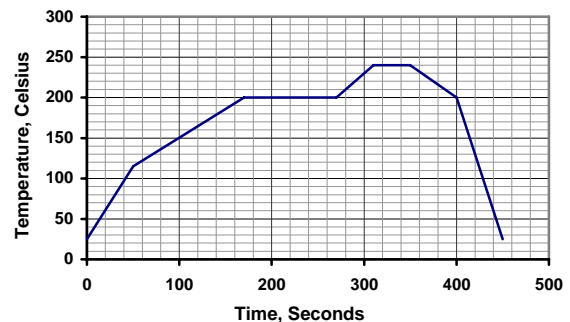

If soldering manually, use the following procedure:

- Tin the contact pads on the module, trying to get more or less the same amount of solder on each. Work on a soft surface so that the components on the topside are not damaged.
- Tin contact pads on main board.
- Place the module in position on the main board.

4. Starting with the pads most likely to be in physical contact, apply heat with a soldering iron to the exposed part of the main board pads. Abut the iron against the edge of the module so that the heat is transmitted to the contact area of the pads. After 10-15 seconds, remove heat. Around 90% of pads should be successfully soldered.
5. Test for continuity between the pad on the upper side of the board and the protruding part of the pad on the main board.
6. Rework non-conducting contacts by applying heat again and a little extra solder.

## Location on main board

The module should be located so that the antenna abuts the edge of the board or overhangs it. It should be placed so that it is unlikely that interfering items such as metal, water, cellphones, body tissue, etc, can come into close proximity.

It is recommended that tracks and components are not placed in PCB layers below the module. However, if space limitations require it, leave the surface in contact with the module uncoppered and place a grounded fill in the layer immediately below. Any vias that might come in contact with the module should be completely covered with resist to avoid shorting to vias on the module. The main board should contain as much grounded copper fill as possible in order to reduce circuit noise.

## Enclosures

Metal enclosures are not recommended for attenuation reasons. If one must be used, aim to put as many holes in it as possible at least 3cm long.

For mains isolation and intrinsic safety applications, potting in a shallow layer of clear potting compound is recommended. A 5mm layer of potting compound (RS Components p/n 199-1468) has been measured to attenuate the signal by approximately 3dB. LEDs can be clearly seen through the potting compound and bind switches, etc, can be implemented using reed switches.

For all-weather and external mounting applications, contact us for a range of puck antenna enclosures.

## Bibliography

**CC2420 Data Sheet**, downloadable from [www.chipcon.com](http://www.chipcon.com).



**ZigBee for Applications Developers**, white paper downloadable from [www.flexipanel.com](http://www.flexipanel.com).

**Pixie Data Sheet**, downloadable from [www.flexipanel.com](http://www.flexipanel.com).

**PICDEM Z User Guide**, downloadable from [www.microchip.com](http://www.microchip.com).

**AN965 Microchip Stack for the ZigBee Protocol**, application note, downloadable from [www.microchip.com](http://www.microchip.com).

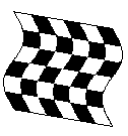
**Microchip Stack for ZigBee Protocol**, supplementary notes included with the Microchip Stack for ZigBee firmware downloadable from [www.microchip.com](http://www.microchip.com).

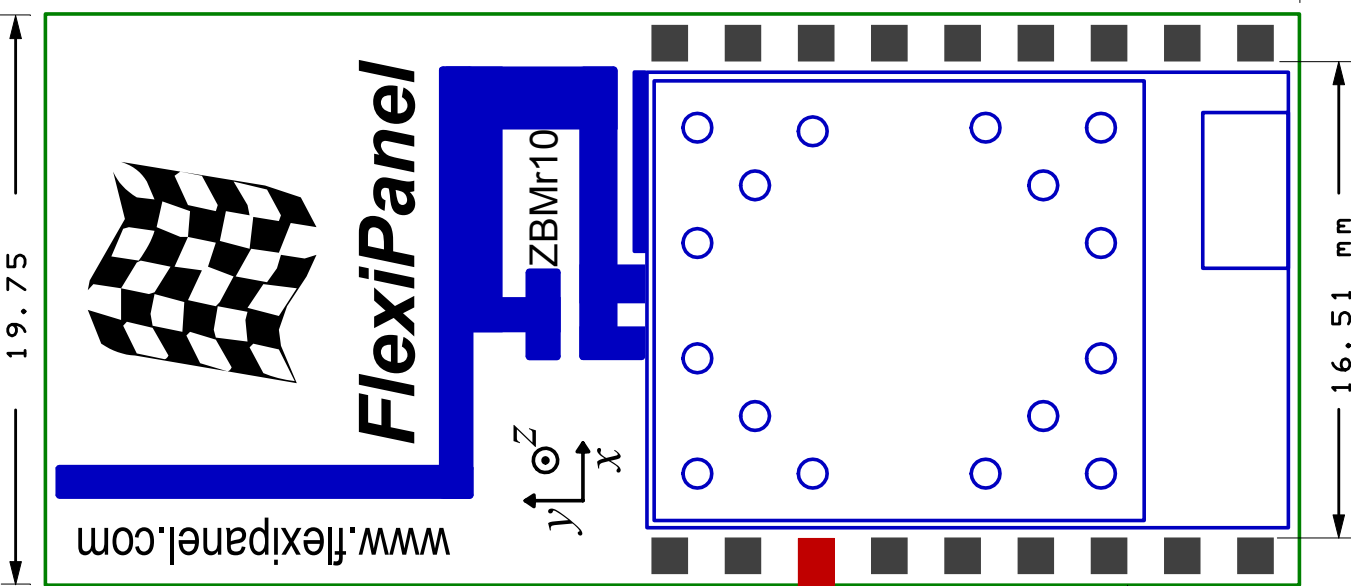
 <p><b>FlexiPanel</b> www.flexipanel.com</p>	<p>Drawing <b>DRWG-ZBMr10</b></p>	<p>Date <b>10 May 06</b></p>	<p>Drawn by <b>R G Hoptroff</b></p>	<p>Description <b>EasyBee IEEE 802.15.4 transceiver module (rev 10)</b></p>	<p><b>Notes</b></p> <ol style="list-style-type: none"> <li>1. Dimensions in mm</li> <li>2. Module height 3.6mm</li> <li>3. Keep antenna side as free of components as possible, preferably overhanging the edge of the main board</li> <li>4. Pour as much grounded copper as possible on the main board, but none on top layer below EasyBee module</li> <li>5. If pins fitted, pin pitch is 20.32mm</li> <li>6. Design is final. FCC, IC and CE compliant</li> </ol>
					
<p>19.75</p>	 <p>Antenna side</p> <p>Electronics side</p> <p>Recommended pad size 3.00 x 1.27</p> <p>2.54</p> <p>0.88</p> <p>16.51 mm</p> <p>43.50</p>	<p>43.50</p>	<p>16.51 mm</p>		

## Reference

### Electrical

Supply Voltage (regulated) Vcc	2.1V to 3.6V
Power requirement, transmit	18mA
Power requirement, receive	20mA

For more information electrical specifications, consult the CC2420 data sheet. (See bibliography.)

### Radio Frequency

Max RF output power	1mW = 0dBm
RF frequency range	2400MHz to 2485MHz
Communications protocol	IEEE 802.15.4 (DSSS O-QPSK chip encoding)
Raw data rate	250kbit/s
RF channels	16
Free space range with integral antenna	Approx 120m

### Mechanical

Max operating/storage temperature	-40°C to +85 °C
Pixie Lite Dimensions LxWxH mm	43.5 x 19.75 x 3.1 (excluding DIL pins)

### Regulatory

FCC compliance	Testing complete, awaiting certificate
CE compliance	Testing complete, awaiting certificate
IC (Industry Canada) compliance	Testing complete, awaiting certificate
FCC external labeling requirement	"Contains Transmitter Module FCC ID:UGAZBMR10"

### Manufacturer Contact Details

EasyBee is assembled and distributed by agreement by RF Solutions Ltd:



RF Solutions Ltd  
Unit 21, Cliffe Industrial Estate,  
Lewes, E. Sussex, BN8 6JL, United Kingdom  
[www.rfsolutions.co.uk](http://www.rfsolutions.co.uk)  
Tel: +44 (0)1273 898 000, Fax: +44 (0)1273 480 661  
email: [sales@rfsolutions.co.uk](mailto:sales@rfsolutions.co.uk)

### Developer Contact Details

EasyBee is designed and owned by FlexiPanel Ltd:



FlexiPanel

FlexiPanel Ltd  
2 Marshall St, 3rd Floor,  
London W1F 9BB, United Kingdom  
email: [support@flexipanel.com](mailto:support@flexipanel.com)  
[www.flexipanel.com](http://www.flexipanel.com)